

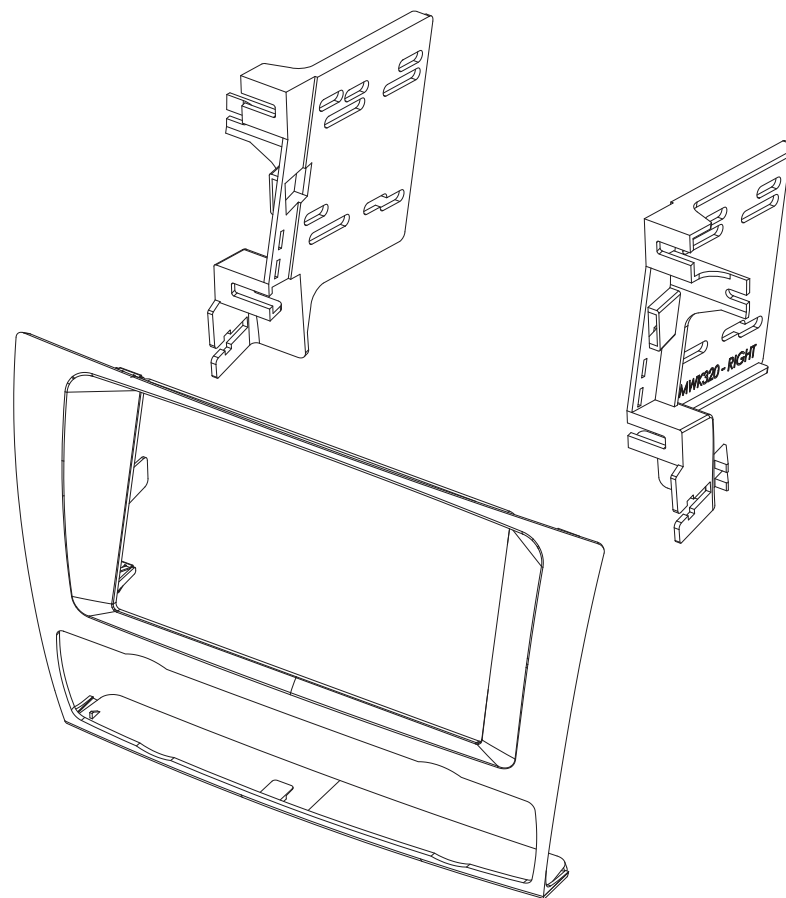

CT23BM21



VEHICLE APPLICATIONS

BMW

2006-11 3 SERIES (without OEM Navigation)

2012-13 3 SERIES Non Sedan (without OEM Navigation)

NOTE: THIS INSTALLATION KIT REQUIRES PROFESSIONAL INSTALLATION. THE OEM CLIMATE CONTROLS WILL NEED TO BE CUT TO MOUNT KIT.

DASH DISASSEMBLY INSTRUCTIONS

1. Carefully remove the climate control assembly unplug harness(s)
2. Remove (2) Phillips Head Screws from the bottom of the OEM Radio.
3. Remove OEM radio and unplug harness(s)
4. Remove (4) Torx screws and (2) Hex Bolts from the OEM bracket and remove.

CLIMATE CONTROL MODIFICATION

1. Remove OEM climate controls from its bezel.
2. Trim climate control at both sides (as shown)

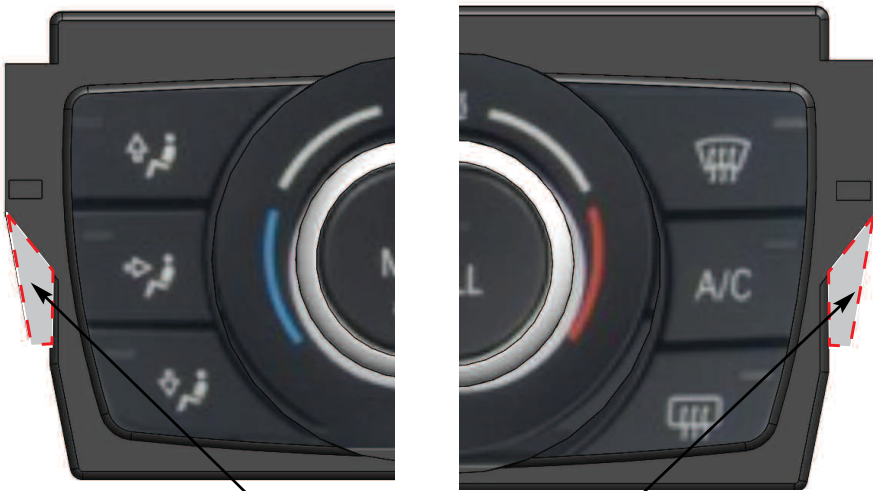

Cut and remove all areas shown in Gray from the OEM CLIMATE CONTROL PANEL

DOUBLE DIN INSTALLATION INSTRUCTIONS

Double DIN Mount Applications

1. Insert ISO mountable radio between ISO mount brackets and loosely attach to sides of radio using screws provided with radio when possible, or screws supplied with kit. Using the main frame of the CT23BM21 as a guide, slide radio forward or backward for desired look and then tighten screws to the radio
2. Install (4) Metal trim clips supplied onto the 4 post located on the main frame.
3. Install climate control into the main frame, paying attention to the bottom center tab located on the main frame making sure it inserts into the OEM climate control correctly.

NOTE: When installing radio with brackets into the sub-dash, the Anchor bracket snaps need to anchor behind the lower sub-dash. Also Set radio as high as possible and use (2) of the OEM Torx screws removed previously to install the bracket.

