

APPLICATIONS

**Nissan 350Z
2006-2008**

CT24NS05

KIT FEATURES

- DIN Radio Provision with pocket
- ISO Radio Provision with pocket
- Two stacked ISO units provision
- Double DIN radio provision



KIT COMPONENTS

- A) Radio Housing with Pocket • B) Double DIN Trim-plate • C) ISO Snap-in Brackets • D) ISO Trim-plate

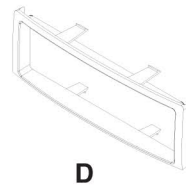
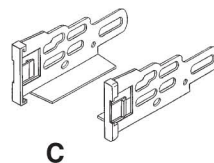
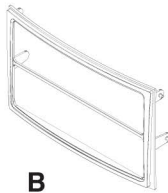
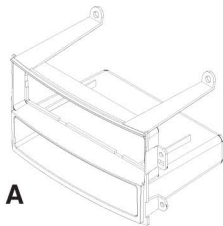

TOOLS REQUIRED:

Panel Removal Tool or Small Flat Blade
Screwdriver

Phillips Screwdriver

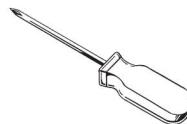
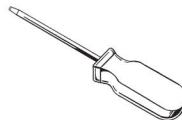

TABLE OF CONTENTS

Dash Disassembly

<i>Nissan 350Z 2006-2008.....</i>	<i>1, 2</i>
--	--------------------

Kit Assembly

<i>Din Mount Radio Provision with pocket.....</i>	<i>3</i>
--	-----------------

<i>ISO Mount Radio Provision with pocket.....</i>	<i>4</i>
--	-----------------

<i>Double DIN Radio.....</i>	<i>5</i>
-------------------------------------	-----------------

<i>Two Stacked ISO mount units.....</i>	<i>6</i>
--	-----------------

<u>Final Assembly</u>	<i>7</i>
------------------------------------	-----------------

NISSAN 350Z 2006-2008

1 Disconnect the negative battery terminal to prevent an accidental short circuit.

2 For vehicles with automatic transmission, Unsnap and remove smaller trim-ring from around shifter. (Figure A)

For vehicles with manual transmission, Unscrew and remove shifter knob. (Figure A)

3 Unsnap and remove center console trim panel including climate controls. (Figure B)

4 For vehicles with navigation, Unsnap and remove navigation switch panel. (Figure C)

5 For vehicles without navigation, remove pocket mat, then remove two screws that secure switch mask. (Figure D)

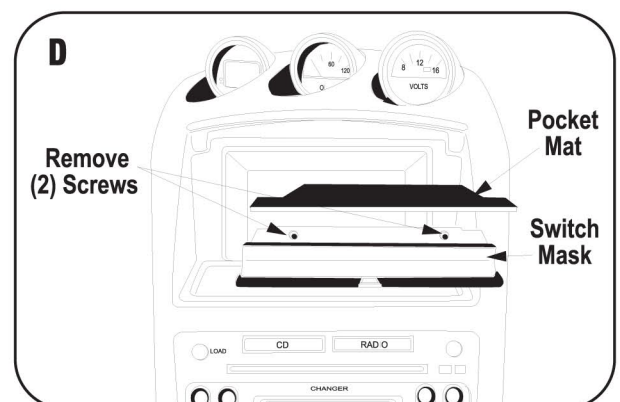
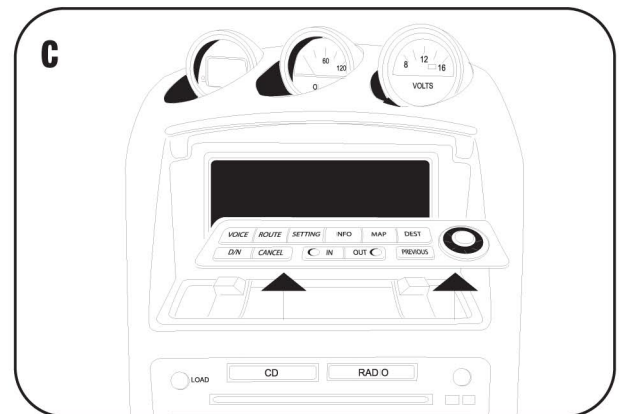
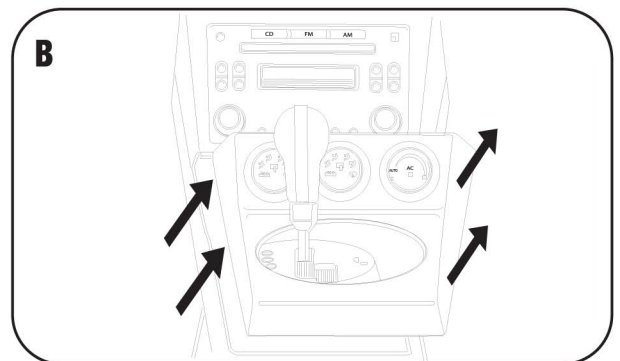
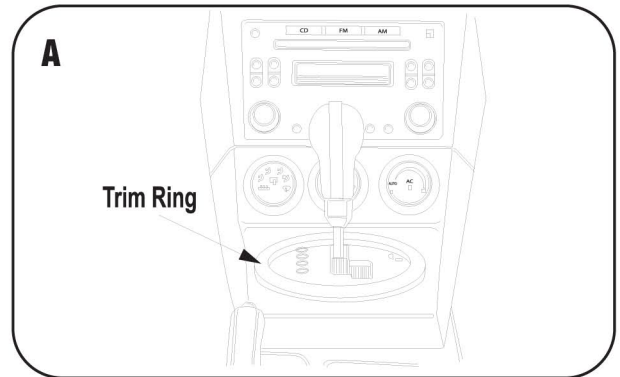

NISSAN 350Z 2006-2008

- 6** Remove (2) screws above the radio and (2) screws below the radio. Also remove (2) screws securing the radio/trim panel assembly. (Figure E)

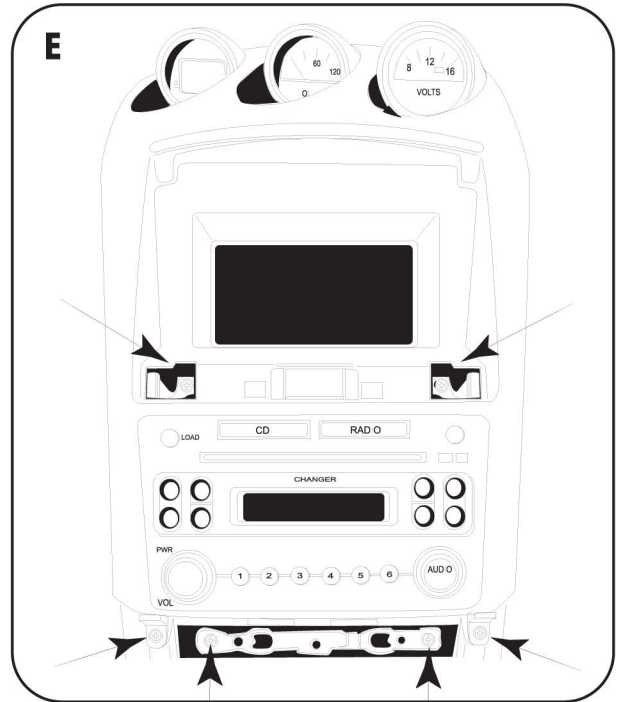

- 7** Unplug and remove the radio / trim panel assembly. (Figure F)

- 8** Remove (4) screws securing the radio to the trim panel and remove the radio.

- 9** Remove (8) screws securing the factory brackets to the radio and remove the brackets from the radio. (These brackets are required for stacked ISO and double DIN installations. You can skip this step for DIN or ISO installations with pocket).

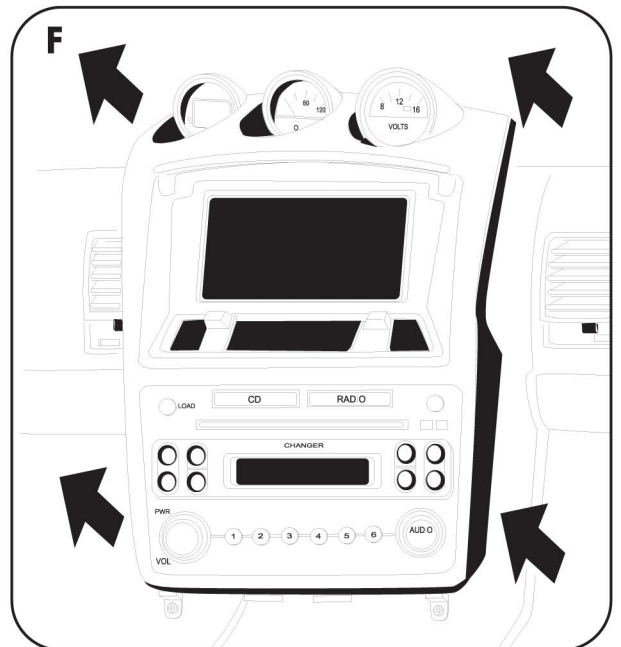

Continue to kit assembly.

DIN MOUNT RADIO PROVISION WITH POCKET

- 1** Slide DIN cage (supplied with radio) into the radio housing from the front. (Figure A)

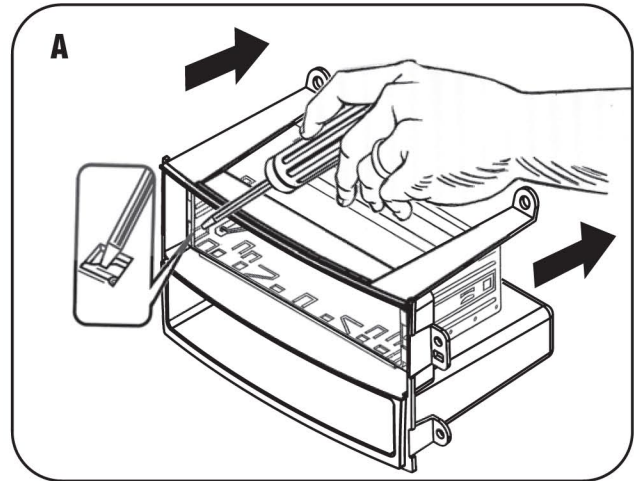

- 2** Secure DIN cage to radio housing by bending the locking tabs outward. (Figure A)

- 3** Slide the radio into the DIN cage until it snaps into place. (Figure B)

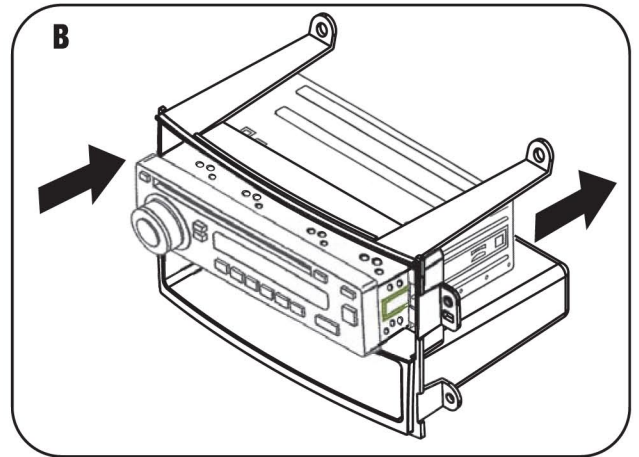

- 4** Attach the radio / housing assembly to the radio trim panel using the factory screws removed during disassembly. (Figure C)

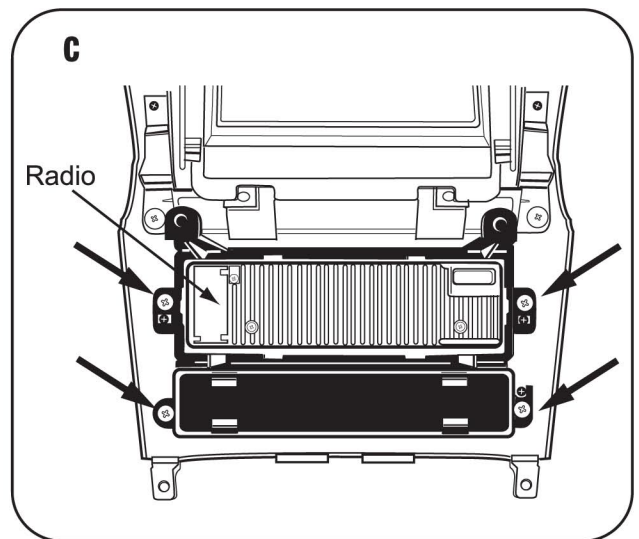

Continue to final assembly.

ISO MOUNT RADIO WITH POCKET

- 1 Align the holes in the ISO brackets with the holes in the radio. Mount the brackets to the radio using screws supplied with the radio. (Figure A)

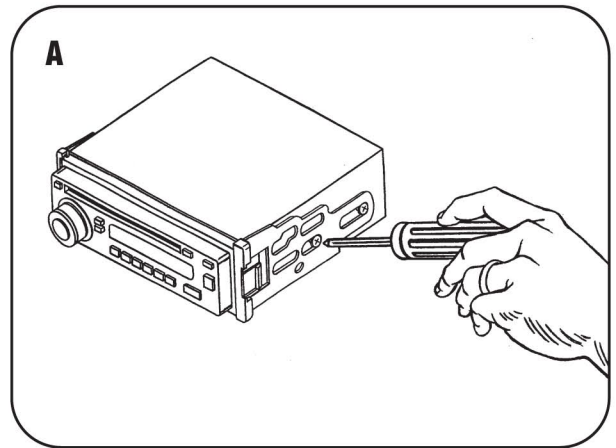

- 2 Slide the radio bracket assembly into the radio housing until it snaps into place. (Figure B)

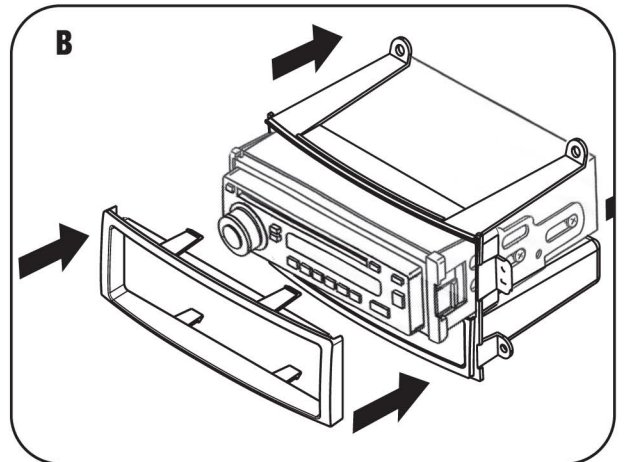

- 3 Snap the ISO trim-plate onto the front of the assembled radio and housing. (Figure B)

- 4 Attach the radio / housing assembly to the radio trim panel using the factory screws removed during disassembly. (Figure C)

Continue to final assembly.

NOTE: To remove the radio unsnap and remove the ISO trim-plate. Using a flat blade screwdriver disengage ISO brackets from the radio housing and slide radio out of radio housing.

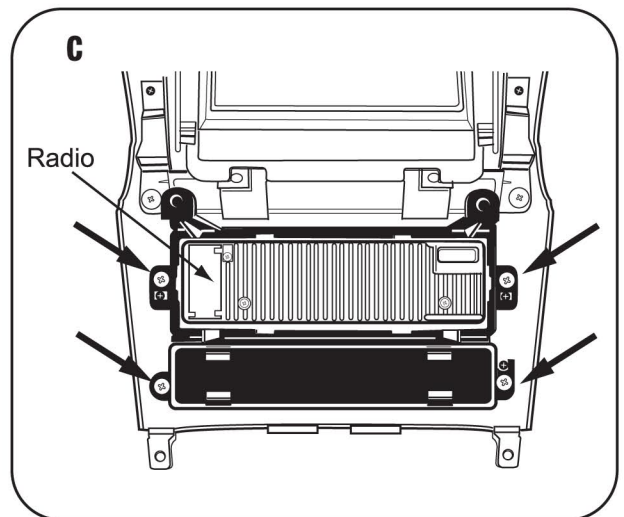

DOUBLE DIN RADIO

- 1** Cut and remove center divider from double DIN trim-plate. (Figure A)
- 2** Place the double DIN trim-plate on the front of the radio. (Figure B)
- 3** Place the right factory mounting bracket (Removed from radio during disassembly) on the right side of the radio. Align the pins on the trim-plate with the holes on the factory bracket and mount the factory bracket to the radio using screws supplied with the radio. (Figure B)
- 4** Place the left factory mounting bracket (removed from radio during disassembly) on the left side of the radio. Align the pins on the trim-plate with the holes on the factory bracket and mount the factory bracket to the radio using screws supplied with the radio. (Figure B)
- 5** Attach the radio bracket assembly to the radio trim panel using the factory screws removed during disassembly. (Figure C)

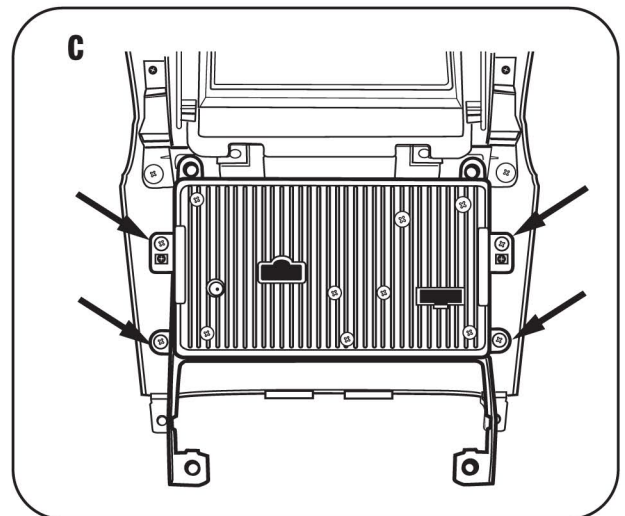
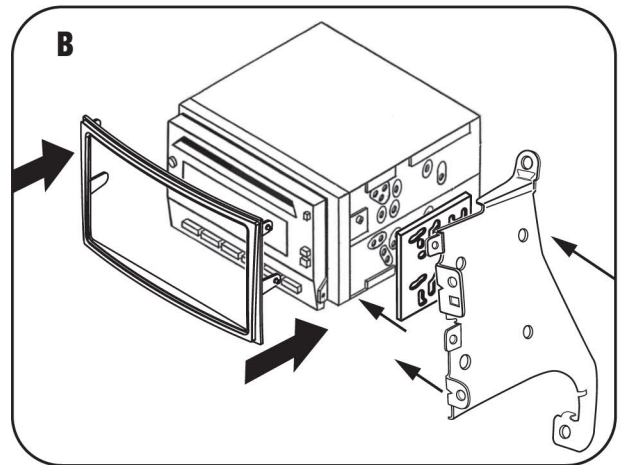
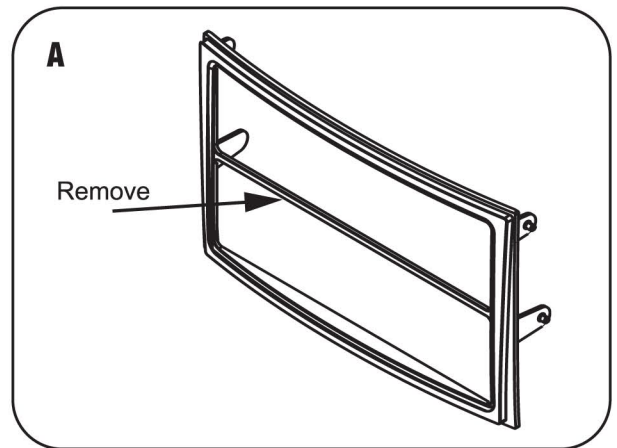

Continue to final assembly.

TWO STACKED ISO MOUNT UNITS

- 1 Place the double DIN trim-plate on the front of the two ISO units. (Figure A)
- 2 Place the right factory mounting bracket (Removed from radio during disassembly) on the right side of the ISO units. Align the pins on the trim-plate with the holes on the factory bracket and mount the factory bracket to the ISO units using screws supplied with the radio. (Figure A)

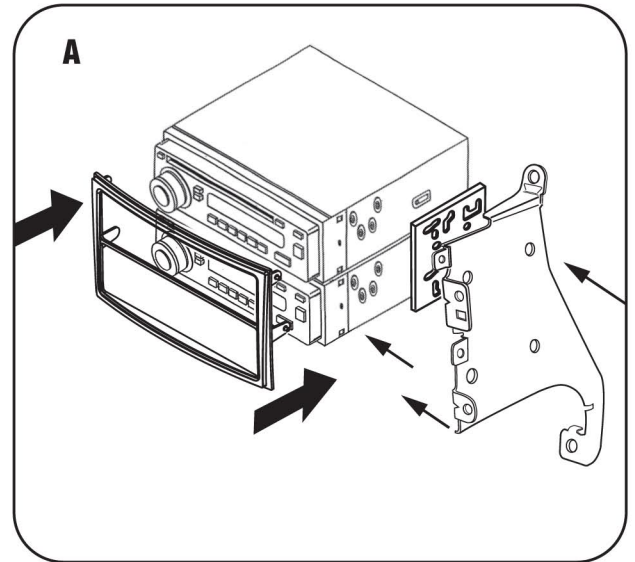

- 3 Place the left factory mounting bracket (Removed from radio during disassembly) on the left side of the ISO units. Align the pins on the trim-plate with the holes on the factory bracket and mount the factory bracket to the ISO units using screws supplied with the radio. (Figure A)

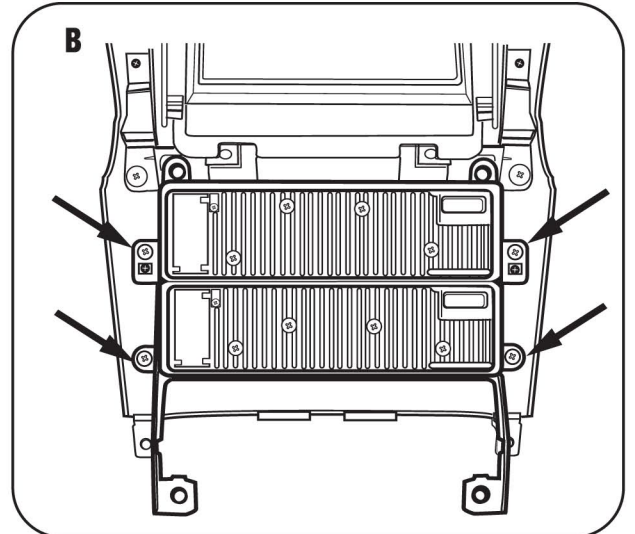

- 4 Attach the assembled units and brackets to the radio trim panel using the factory screws removed during disassembly. (Figure B)

Continue to final assembly.