

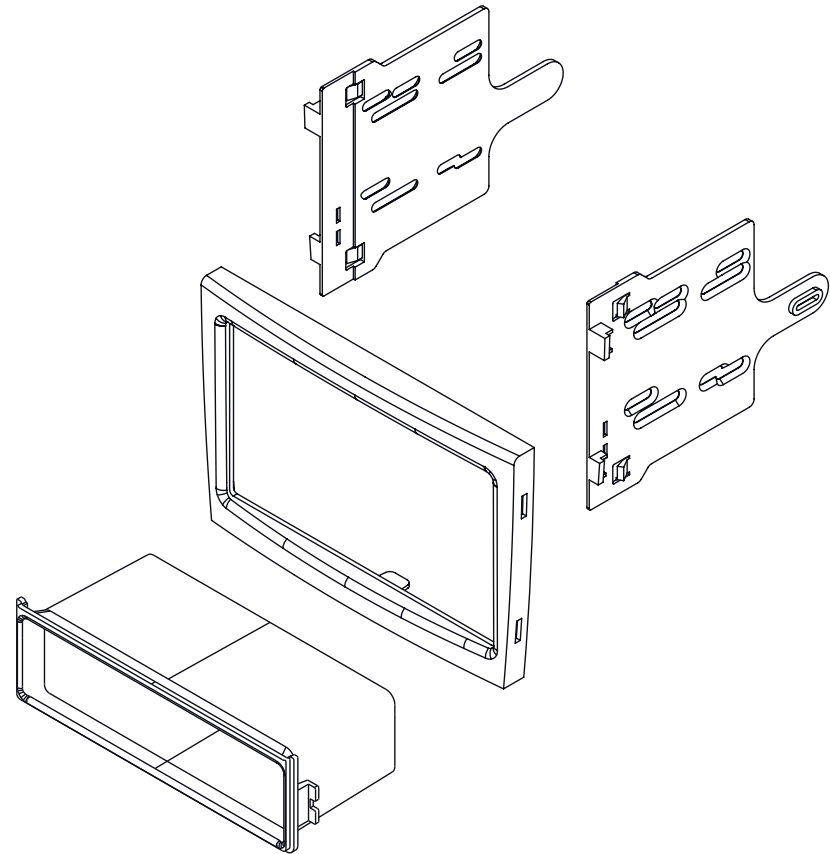

...connecting to the aftermarket

CT24P003



VEHICLE APPLICATION

Porsche

2005-11 Porsche 911

2005-11 Porsche Boxster

2005-11 Porsche Cayman

DASH DISASSEMBLY INSTRUCTIONS

1. Remove (1) T-25 screw from each lower rear carpet panel, located to the left and right of the radio.
2. Remove (2) T-20 screws from each of the now exposed rear bottom side radio trim.
3. Unsnap and remove radio side trim pieces from the left and right of the radio.
4. Remove/Loosen (1) 7mm bolt from the right side of the radio.
5. Turn the (4) 5mm female Allen/Hex head screws counter clockwise, until they stop.
6. Remove radio. Unplug all harnesses.

SINGLE ISO w/POCKET INSTALLATION INSTRUCTIONS

This is a pressure fit kit, there are no screw or bolt mounting locations. Install kit carefully.

1. Insert ISO brackets to rear of kit as shown in Figure A.
2. Insert pocket into lower section of kit from rear & lock into slots of mounting brackets.
3. Insert ISO mountable radio between ISO mount brackets and loosely attach to sides of radio using the (4) counter sunk screws.
4. Slide radio forward or backward for desired look and tighten screws.
5. When installing the kit/radio into the dash opening...make sure the lower center locator stud and the left and right rear side support studs are lined up correctly. The rear support rail has no middle support.

NOTE #1: For Single ISO installation using pocket. When snapping kit in dash you must push the lower pocket tabs past the sub-dash.

NOTE #2: If you need to remove the kit/radio once the CT24PO03 is snapped into the dash, using a soft tool unsnap mainframe bezel from brackets and depress all 4 plastic snaps on the left and right sides.

Fig A

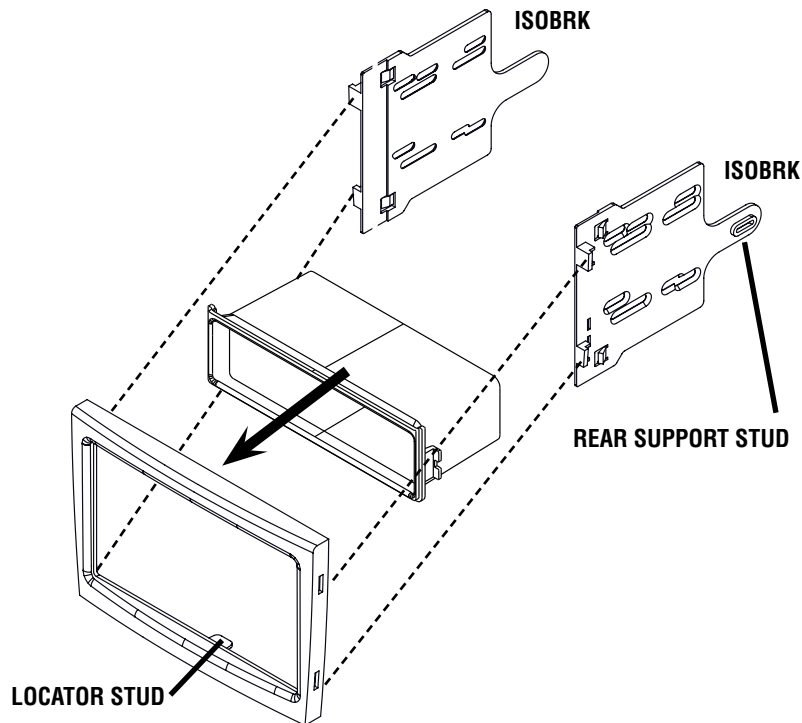

DOUBLE DIN INSTALLATION INSTRUCTIONS

This is a pressure fit kit, there are no screw or bolt mounting locations. Install kit carefully.

1. Attach ISO brackets to the rear of the main mounting kit.
2. Slide radio into kit from rear & attach to ISO mounting brackets using the (8) counter sunk screws supplied with kit (do not tighten screws at this time).
3. Slide radio forward or backward for your desired look and then tighten the mounting screws.
4. When installing the kit/radio into the dash opening...make sure the lower center locator stud and the left and right rear side support studs are lined up correctly. The rear support rail has no middle support.

NOTE: If you need to remove the kit/radio once the CT24PO03 is snapped into the dash, using a soft tool unsnap mainframe bezel from brackets and de-press all 4 plastic snaps on the left and right sides.

Fig B

